

Pre-moulded Cable Accessories

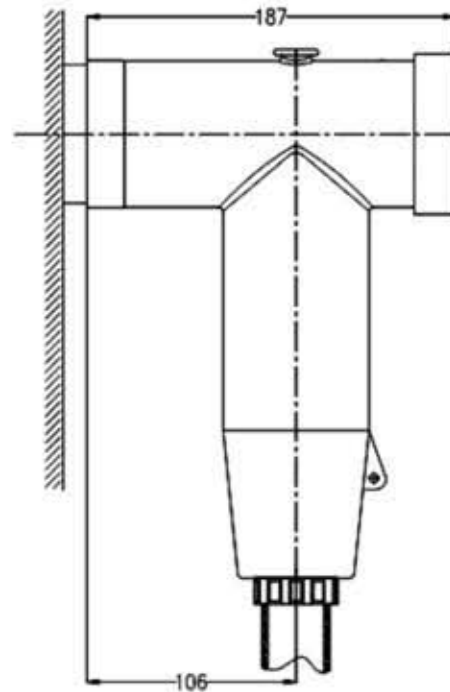

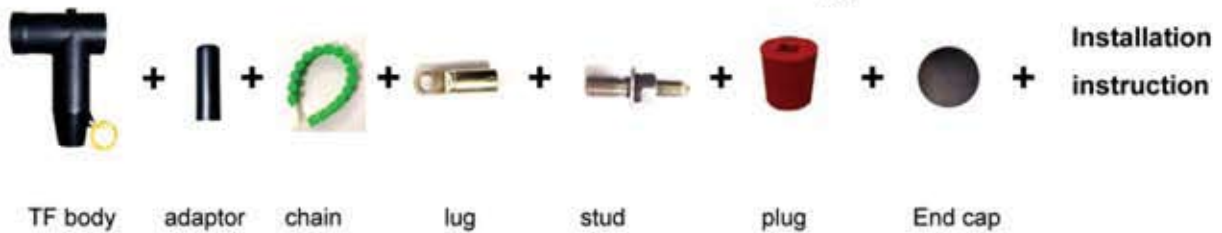

Main components:



Type option table

type	12/20kV cable conductor cross section(mm ²)	Adaptor size
AQT3-24/630/35	35	Φ 16
AQT3-24/630/50	50	Φ 16
AQT3-24/630/70	70	Φ 19
AQT3-24/630/95	95	Φ 19
AQT3-24/630/120	120	Φ 19
AQT3-24/630/150	150	Φ 23
AQT3-24/630/185	185	Φ 23
AQT3-24/630/240	240	Φ 26
AQT3-24/630/300	300	Φ 26
AQT3-24/630/400	400	Φ 30
AQT3-24/630/500	500	Φ 30
AQT3-24/630/630	630	Φ 34

TRANSEAL-HS

24KV T Type Rear Connector

630 A Series Products

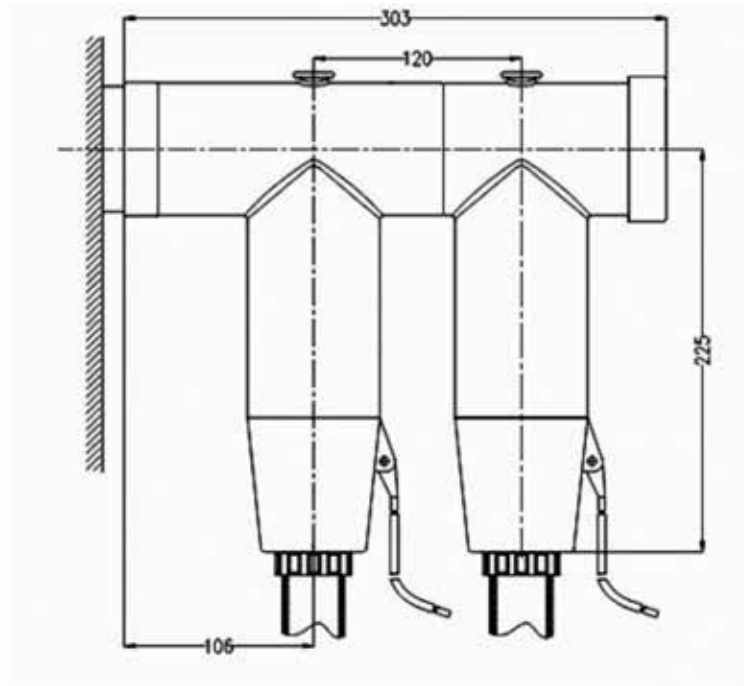

Main components:



Type option table

type	12/20kV cable conductor cross section(mm ²)	Adaptor size
AHT3-24/630/35	35	Φ 16
AHT3-24/630/50	50	Φ 16
AHT3-24/630/70	70	Φ 19
AHT3-24/630/95	95	Φ 19
AHT3-24/630/120	120	Φ 19
AHT3-24/630/150	150	Φ 23
AHT3-24/630/185	185	Φ 23
AHT3-24/630/240	240	Φ 26
AHT3-24/630/300	300	Φ 26
AHT3-24/630/400	400	Φ 30
AHT3-24/630/500	500	Φ 30
AHT3-24/630/630	630	Φ 34

GTP for 24KV

Characteristics	Guaranted Value
A C High Voltage	54 kv AC for 5 minutes
- Partial Discharge	≤ 10 pc at 20 kv
Impulse test	125 kv

* A hongshang product